

# Case

Date:22.04.2026

Article number: 105 001-11



# Table of content

Information .....	3
Measurements .....	3
Colors .....	3

## Information

AppliCases are the attractively designed all-rounders among service cases. They are produced individually, customised for the specific purpose. The structure made of impact-resistant polyethylene provides the necessary robustness in tough working environments just as much as carrying convenience due to their low weight.

AppliCases are the optimal carry case for everyone who has to rely on their instruments and tools during their daily work.

Equipped with a handle on the frontside you can use the industry case as a toolcase, equipment case or special case.

## Measurements

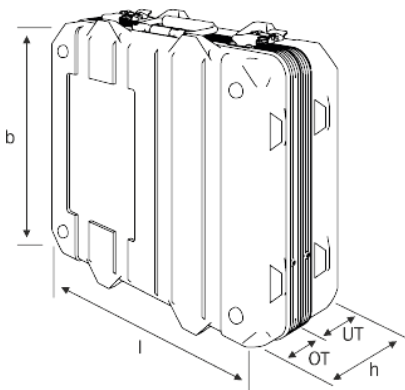

Interior (l x w x h (base + lid)) [mm]:  
429 x 298 x 155 (85 + 70)

Exterior (l x w x h (base + lid)) [mm]:  
460 x 360 x 190 (105 + 85)

Weight 4,2 kg

## Colors



RAL: similar to  
9011, black



RAL: similar to  
6014, army green



RAL: similar to  
9010, white



RAL: similar to  
9007, silver grey



RAL: similar to  
1021, yellow



RAL: similar to  
2004, orange



RAL: similar to  
2002, red



RAL: similar to  
5002, blue



RAL: similar to  
7016, dark grey



RAL: similar to  
1002, desert tan

# Contact

Date:22.04.2026

## Thermodyne GmbH

Nordstr. 15

49086 Osnabrück

Dr.-Ing. Daniel Bätzel

+49 (0) 541 / 181 4997-95

[www.thermodyne.de](http://www.thermodyne.de)

[info@thermodyne.de](mailto:info@thermodyne.de)